

- NOTES:
- UNLESS OTHERWISE SPECIFIED:
  - CAPACITANCE VALUES OF 1 OR GREATER ARE IN PICOFARADS, 10%, 500V.
  - CAPACITANCE VALUES OF LESS THAN 1 ARE IN MICROFARADS, 10%, 500V.
  - RESISTORS ARE 1/4WATT, 5%.
  - VOLTAGES WERE MEASURED WITH A VTVM UNDER THE FOLLOWING CONDITIONS:  
POWER AND ODB METER RANGE TOUCH CONTROLS ACTIVATED. MASTER POWER SWITCH, S11, IN THE ON POSITION. SPEAKER SWITCH, S1, IN THE OFF POSITION. INPUT LEVEL CONTROLS, R2 AND R3, ROTATED COMPLETELY COUNTERCLOCKWISE, ∞ POSITION. NO INPUT SIGNAL. LINE MAINTAINED AT 120VAC. ALL VOLTAGE MEASUREMENTS ARE POSITIVE WITH RESPECT TO GROUND.
  - S1, SPEAKER SWITCH, SHOWN IN THE OFF POSITION.
  - ⊕ INDICATES POWER SUPPLY GROUND, ⊕ INDICATES CHASSIS GROUND, AND ⊕ INDICATES SIGNAL GROUND.
  - RESISTANCE MEASUREMENTS ON TRANSFORMER AND RELAY WINDINGS TAKEN WITH UNIT UNPLUGGED FROM LINE.
  - ARROWS — ON CONTROLS INDICATE CLOCKWISE ROTATION.
  - \* PART RAISED 1/4 INCH ABOVE BOARD.
  - ⊙ INDICATES VOLTAGE TAKEN WITH -20DB METER RANGE TOUCH CONTROL ACTIVATED.
  - ⊕ INDICATES VOLTAGE TAKEN WITH FILTER TOUCH CONTROL ACTIVATED.
  - ⊕ INDICATES VOLTAGE TAKEN WITH THE MASTER POWER SWITCH, S11, IN THE ON POSITION, AND POWER TOUCH CONTROL DEACTIVATED.
  - TRANSISTORS SURROUNDED WITH A DOTTED LINE INDICATE TRANSISTOR IS MOUNTED TO A HEATSINK.
  - ⊕ INDICATES LATE PRODUCTION.
  - ⊕ PART WAS .47A. IN EARLY PRODUCTION.
  - ⊕ PART WAS .47A. IN EARLY PRODUCTION.
  - ⊕ PART WAS .33A. IN EARLY PRODUCTION.

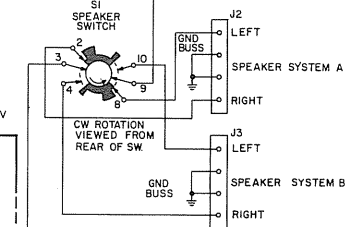

REVISIONS	PHILIPS HIGH FIDELITY LABS PO BOX 1000 PHILADELPHIA, PA 19106
SCHEMATIC - 22AH578	
DATE	9/20/77
BY	EL
CHK	EL
APP	EL
REV	E
REV NO	EL3220-1

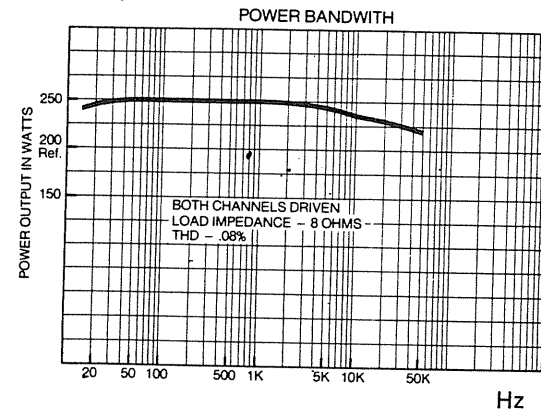
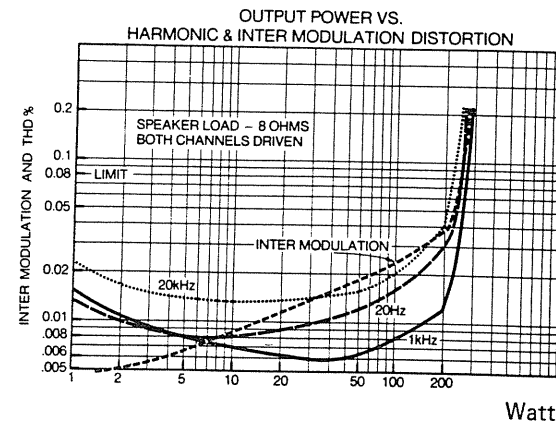
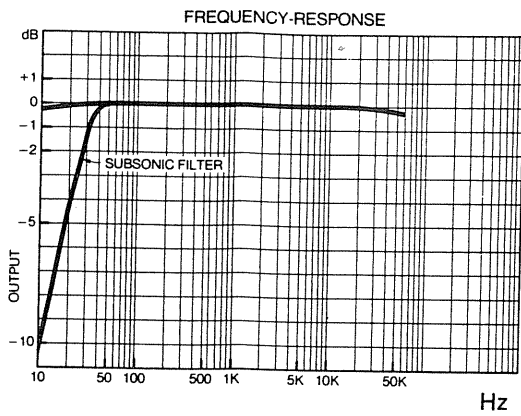
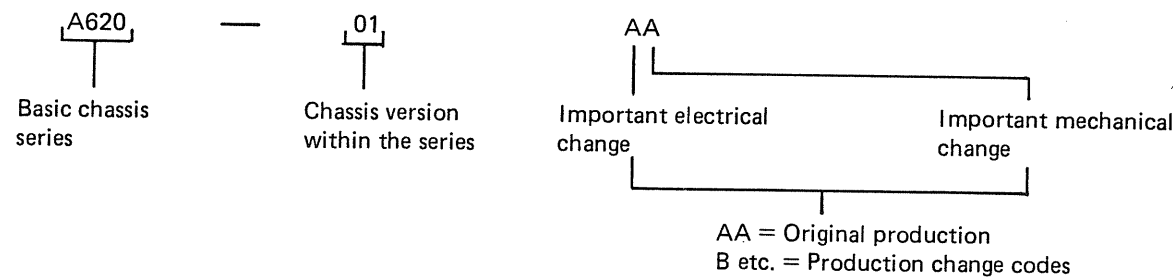

Fig. 3

CHASSIS IDENTIFICATION



INSTRUCTIONS FOR SERVICING AND REPLACING PARTS

Driver and output transistor replacement

Since transformerless quasi complementary output circuitry is utilized in this chassis, extreme care should be exercised when servicing or replacing the transistors. It is imperative that the transistors be isolated from the heat sink by means of a mica insulator coated on both sides with Dow-Corning DC4 silicon grease, or equivalent

When replacing a driver or output transistor, make certain the replacement transistor has the same beta range (i.e., Orange or Red) as the defective transistor. The beta range of the transistor is indicated by a red or orange dot (or lettering) on the top of the case. Failure to replace a defective driver or output transistor with one having the same beta characteristics could be detrimental to the performance of the power amplifier.

After servicing or replacing one or more of the output transistors, the Quiescent Current Adjustment must be performed in the affected channel. Misadjustment of the output transistors will cause crossover distortion and possible premature failure of the output transistors.

Driver board assembly service position

For ease in troubleshooting and servicing the components located on the driver board assembly, disassemble the chassis as follows:

1. Remove the cabinet top (1) and bottom pan from the power amplifier.
2. Remove the four safety screens from the large heat sink to which the driver board assembly, that is to be serviced, is mounted to.
3. To obtain additional slack for the wires connected to the thermal switch (mounted on the large heat sink), remove the wires from the nylon tie located on the bottom of the chassis.
4. Remove the eight screws securing the large heat sink to the chassis. The driver board assembly/heat sink can now be removed from the chassis by gently rocking it back and forth while, at the same time, lifting it up and out of the chassis. When the driver board assembly/heat sink is released from the chassis,

be careful not to damage the wires connected to the thermal switch.

5. The driver board assembly/heat sink can now be laid down along side the chassis.
6. Connect the extender cables between P201 and J201, and between P202 and J202. Power can now be applied to the chassis, when it is in the driver board assembly service position, for troubleshooting the circuitry contained on the driver board assembly. For extender cable fabrication instructions, see "Extender Cable Fabrication".
7. To reassemble, reverse the preceding steps.

Extender cable fabrication

A set (two cables) of extender cables must be fabricated to power the chassis when in the Driver Board assembly position. Fabrication of a single cable is as follows:

1. The materials required to fabricate a single extender cable are listed below:

Qty	Description
8	127 mm lengths of insulated 18 gauge solid wire
1	4822 265 30151, 8-pin male connector
1	4822 265 30155, 8-pin female connector

2. Prepare the eight lengths of wire by removing 6 mm of insulation from each end.
3. Tin the wire ends, as well as the connector terminals on the male and female connectors.
4. Using one of the prepared lengths of wire, connect pin 1 of the male connector to pin 1 of the female connector. Continue wiring the connectors in this manner until the remaining seven pins of each connector have been connected to one another.

Replacement of components secured to chassis by rivets

1. Bore out the rivets using a drill bit slightly larger in diameter than the rivet, see Figure. 4.
2. Punch out the remainder of the rivet with a nail set or prick punch.
3. Remove the defective components.
4. Install the new component by securing it with another rivet, or suitable screw and nut.

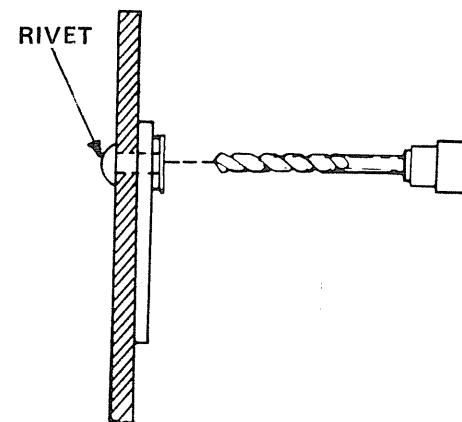

Fig. 4

ADJUSTMENTS

Quiescent current adjustment

To adjust the direct coupled quasi complementary output stage, perform the following adjustment on each Driver Board assembly:

1. Place the speaker switch to the "Off" position.
2. Rotate the level controls completely counterclockwise (no input signal).
3. Connect a DC VTVM across R234.
4. Adjust R220 (Idle Range) to read 45 mV,  $\pm$  5 mV, on the DC VTVM as soon as the amplifier is turned On (cold).

*Note: This adjustment must be performed in the affected channel when any of the output transistors are replaced. Misadjustment will cause crossover distortion and possible premature failure of the output transistor(s).*

Level meter adjustment

To adjust the level meters perform the following adjustments, left channel and (right channel), on the front board assembly:

1. Disconnect J105 from P105.
2. With the "0 dB" (X1) meter range activated, couple a 200 mV, 1,000 Hz signal to pin 2 (1) of P105.
3. Connect an AC VTVM to the positive terminal of C119 (IC120), and adjust R140 (R141) until 105 mV is indicated on the meter.
4. Connect J105 to P105.
5. Connect an AC VTVM to the left (right) channel speaker system "A" terminals, and place the speaker switch in the "A" position.
6. Rotate the left (right) channel level control to mid-position. Apply a 1,000 Hz signal to the left (right) channel input jack and adjust the generator output until 40 VAC is indicated on the AC VTVM.
7. Adjust R152 (R146) until 0 dB is indicated on the power amplifiers left (right) channel level meter.

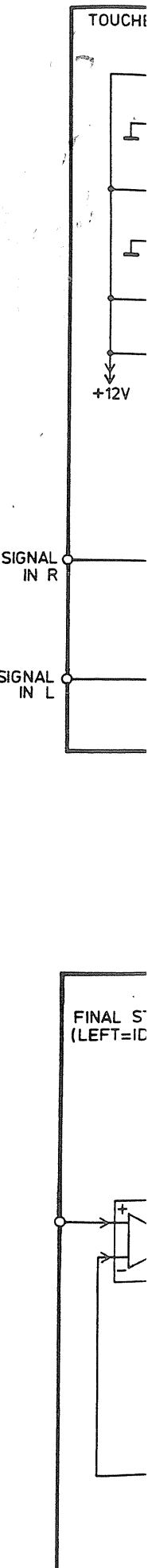

dB  
 +1  
 0  
 -1  
 -2  
 -5  
 -10  
 OUTPUT  
 10 mV, on  
 ned On

in the  
 nsistors  
 ossover  
 of the

adjust-  
 ie front

, couple  
 if P105.

signal of  
 105 mV

channel  
 speaker

to mid-  
 ft (right)  
 r output

INST.  
 PART

Driver

since  
 circuit  
 e exe  
 is in  
 at si  
 les w

ten  
 tain  
 ge  
 be  
 rge  
 epl.  
 ha  
 me

si  
 ist  
 rrr  
 t  
 le  
 51

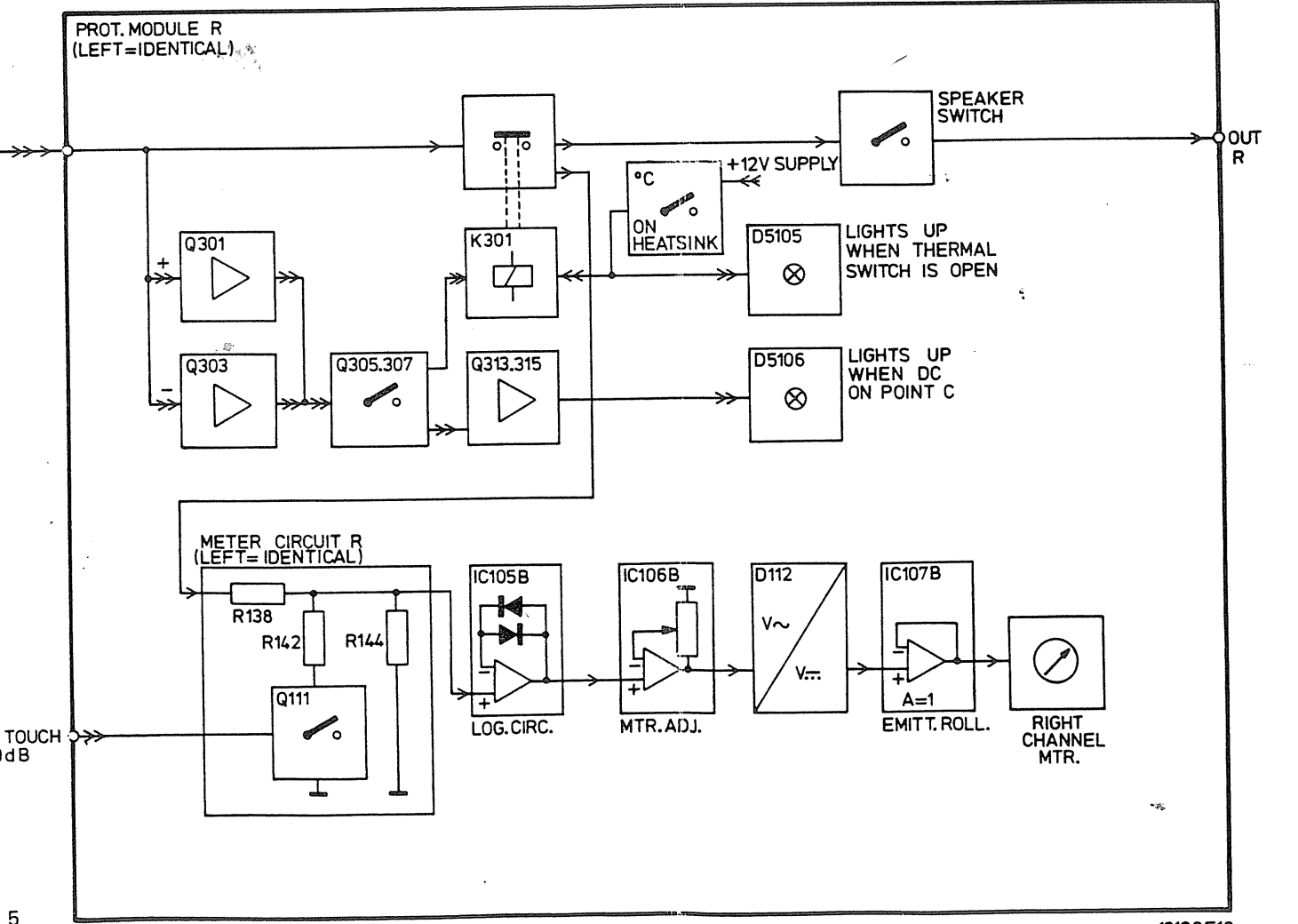
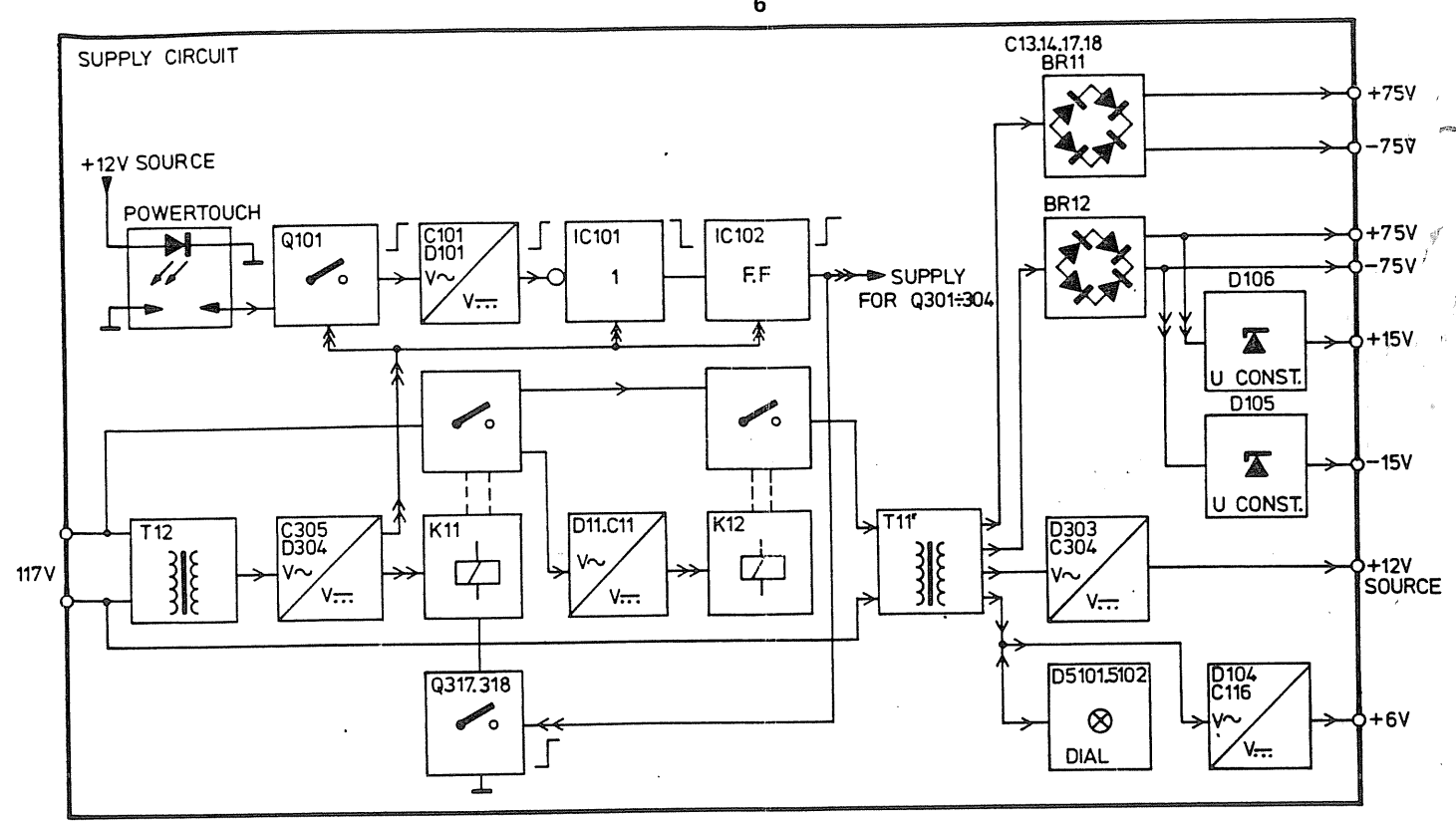
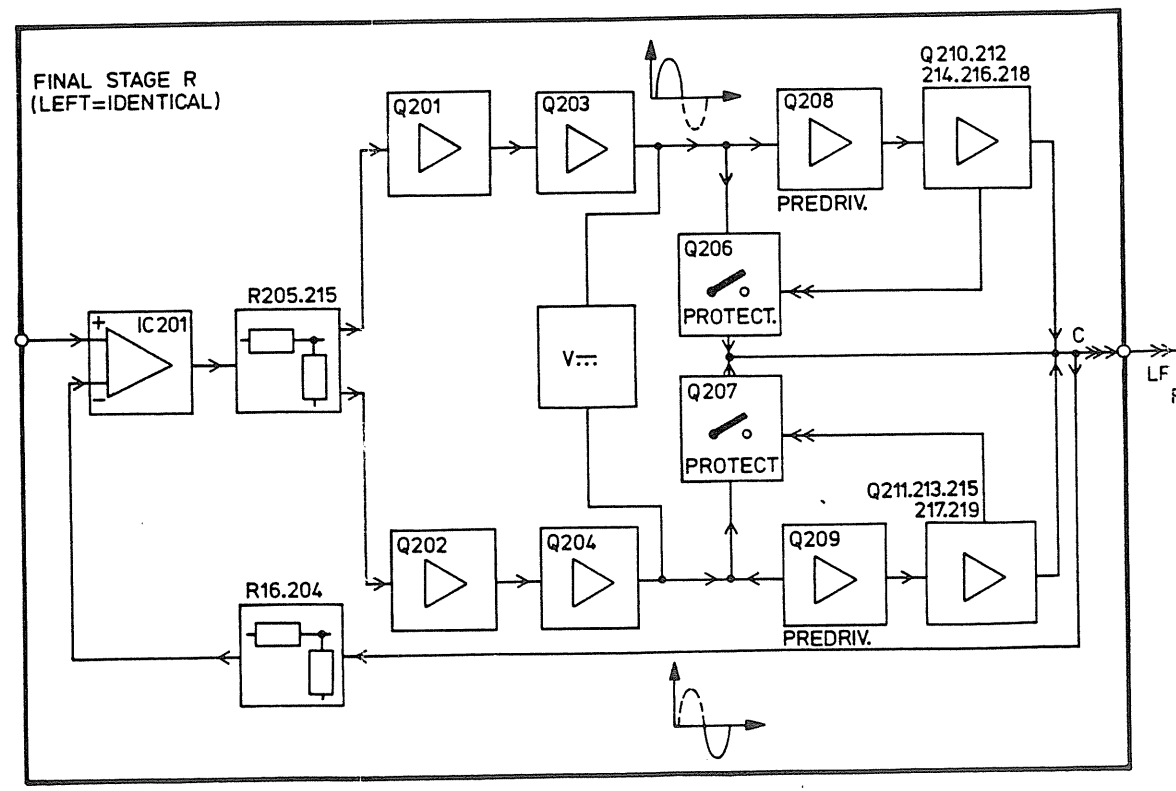
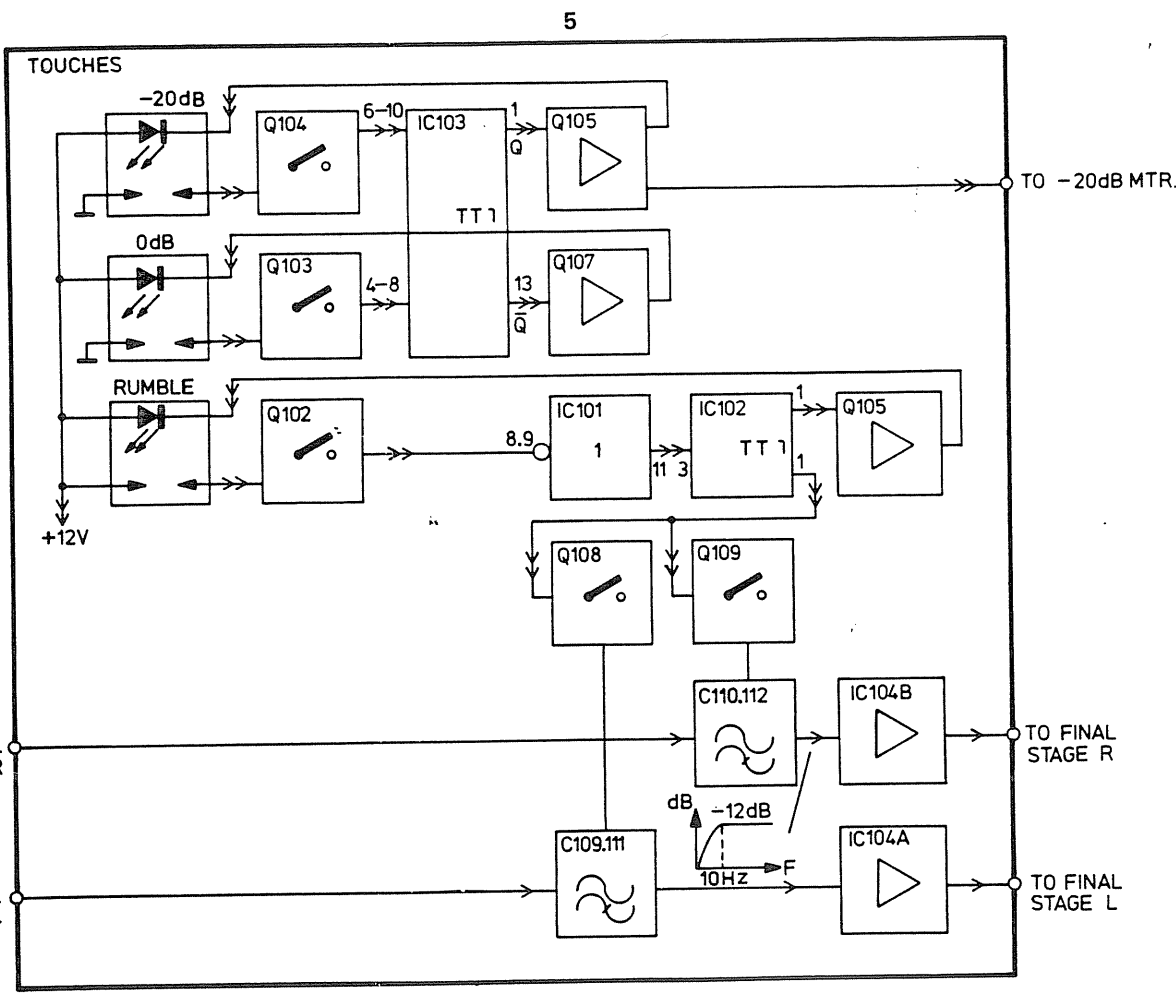

Fig. 5

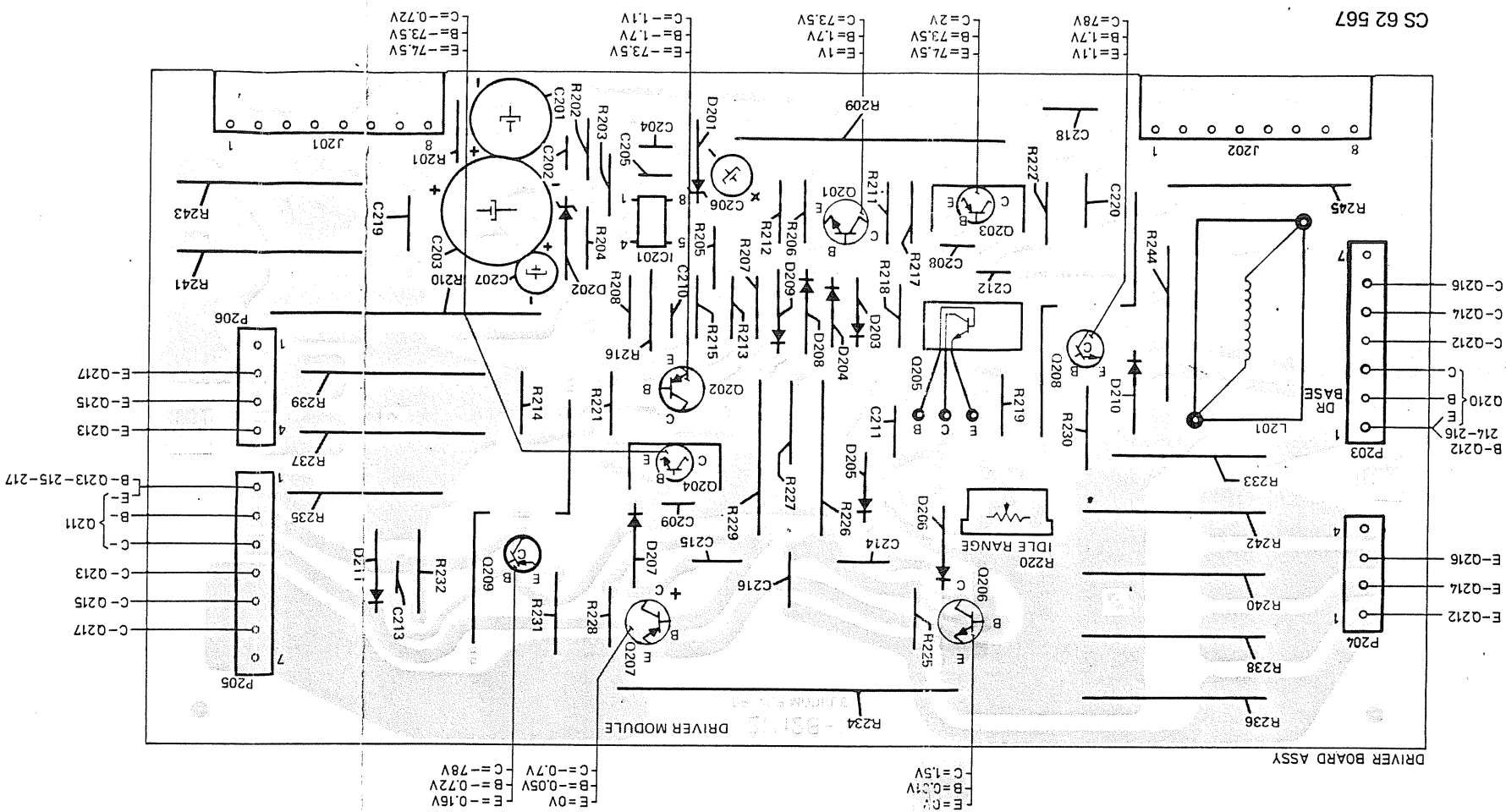
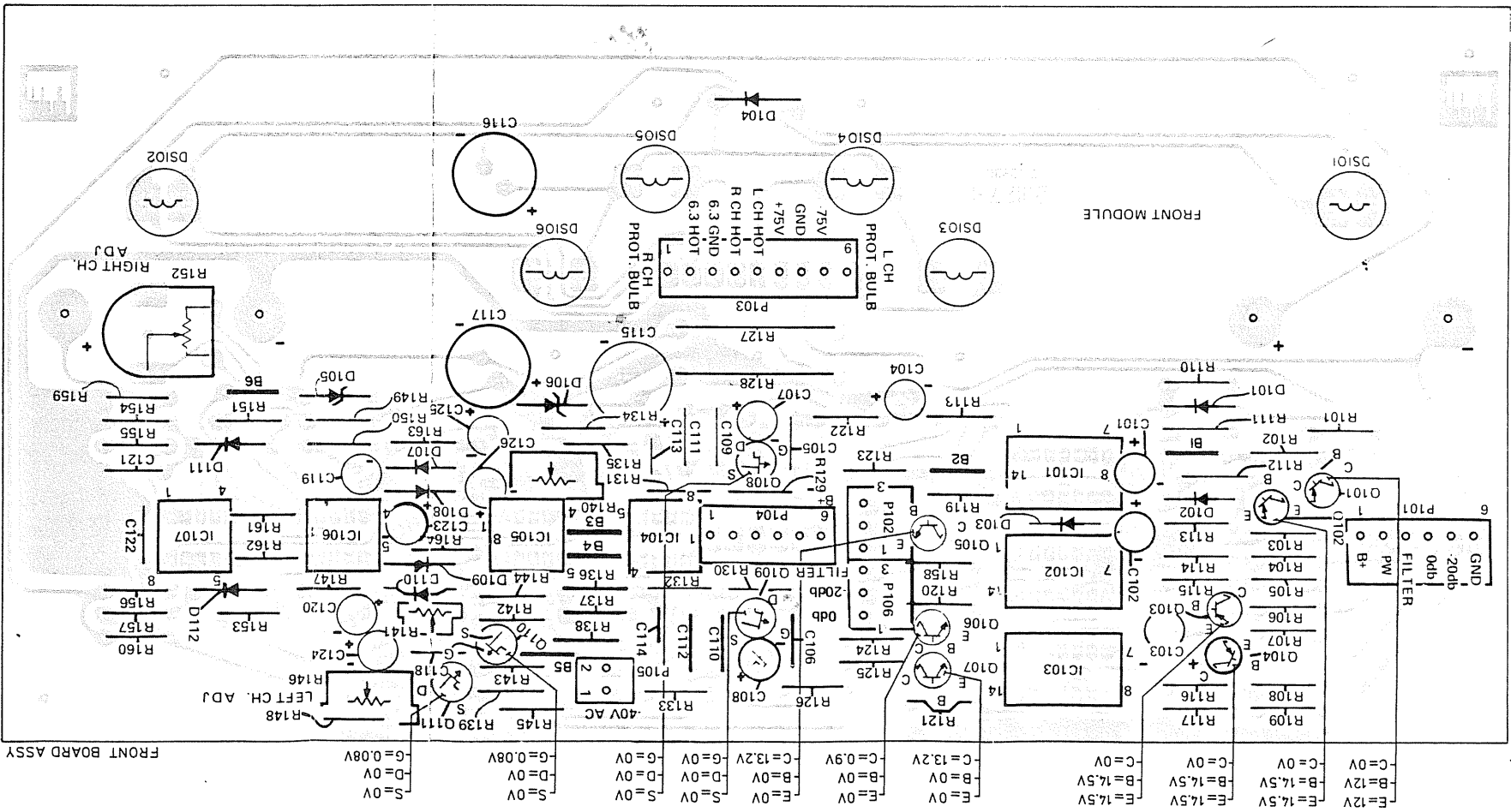
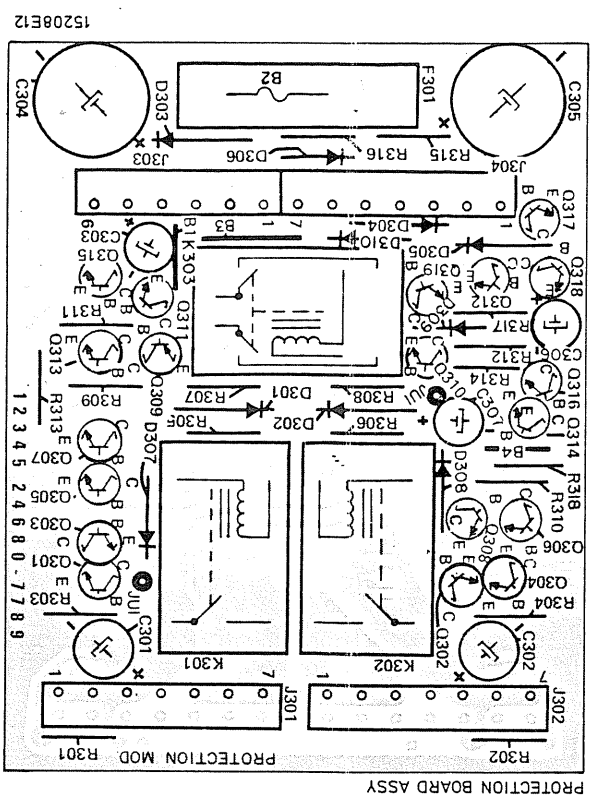

Fig 6



Q318	0V	0.9V	0.9V
Q317	0.9V	1.6V	0.9V
Q316	0V	0.42V	8V
Q315	0V	0.42V	8V
Q314	0.42V	0.65V	8V
Q313	0.42V	0.65V	8V
Q312	0V	0V	8V
Q311	0V	0V	8V
Q310	14.5V	14V	0V
Q309	14.5V	14V	0V
Q308	0V	0.7V	0.78V
Q307	0V	0.7V	0.78V
Q306	0.7V	1.25V	0.78V
Q305	0.7V	1.25V	0.78V
Q304	0V	0V	1.25V
Q303	16V	0V	1.25V
Q302	0V	0V	1.25V
Q301	0V	0V	1.25V
		B	C

